



# INSTRUCTION AND SAFE USE MANUAL

## SHADOW SAFETY HARNESS WITH SUSPENSION RELIEF AND DEER DRAG

REVISED: 03/11/2020



### WARNING!

Read, watch, understand and follow all written and DVD instructions prior to using any Hunter Safety System (HSS) product. Failure to read, watch, understand and follow this information could result in not being able to return to the stand causing extended suspension in the harness after a fall which can lead to serious injury or death!

If there is *ANYTHING* about any HSS product or instructions that you do not fully understand, call HSS at 1-877-296-3528 and speak with a product specialist **BEFORE** using your harness or any HSS product! If you call after hours or when a product specialist is not available, call again until you speak with a product specialist who clarifies anything you do not completely understand before using any HSS product.

**REMEMBER!!**  
FILL OUT AND RETURN THE  
**WARRANTY  
CARD**  
AT THE END OF THIS BOOKLET

### TABLE OF CONTENTS

Package Contents	2
Harness Diagram	2
Adjusting Your Harness	3
Attaching Your Harness / Vest to the Tree	3
Using the Suspension Relief Strap / Deer Drag	3 - 4
Use with Various Treestand Styles	4
Safe Use Instructions and Hunting Practices	5 - 6
Limited Warranty Information	7
Warranty Card	7

**IF YOU HAVE ANY QUESTIONS ABOUT THIS OR ANY HUNTER SAFETY  
SYSTEM PRODUCT, CALL A PRODUCT SPECIALIST AT 1-877-296-3528.**

**HUNTERSAFETYSYSTEM.COM**

© 2020 Hunter Safety System, Inc. | 8237 Danville Road, Danville, Alabama 35619 | 877-296-3528 | questions@hssharness.com

# PACKAGE CONTENTS

Your SHADOW Harness includes one each of the following:

- SHADOW Harness
- Tree Strap
- Suspension Relief Strap / Deer Drag (attached to harness)
- Instruction and Safe Use Booklet
- Instructional DVD

## WARNING!

This harness DOES NOT include a Lineman's Climbing Strap. A Lineman's Climbing Strap must be used when installing or removing hang-on style treestands or tree climbing aids (i.e. ladder sticks, steps). Follow all Lineman's Climbing Strap instructions included with the strap. HSS Lineman's Climbing Straps are available at local and online sporting good stores and at [huntersafetysystem.com](http://huntersafetysystem.com). You may also call 1-877-296-3528 to order over the phone.

**PLEASE NOTE:** Although every component has been examined for quality compliance by HSS, all components must be examined by the user before each use to assure there is no damage or wear etc. Call 1-877-296-3528 and speak with an HSS product specialist before use if any of the contents are missing.

# HARNESSES DIAGRAM

1. Chest Strap
2. Shoulder Adjustments
3. Suspension Relief / Deer Drag Strap
4. Lineman's Climbing Belt Loops
5. Leg Buckles
6. Leg Strap Adjustments
7. Tether
8. Break-Away Straps

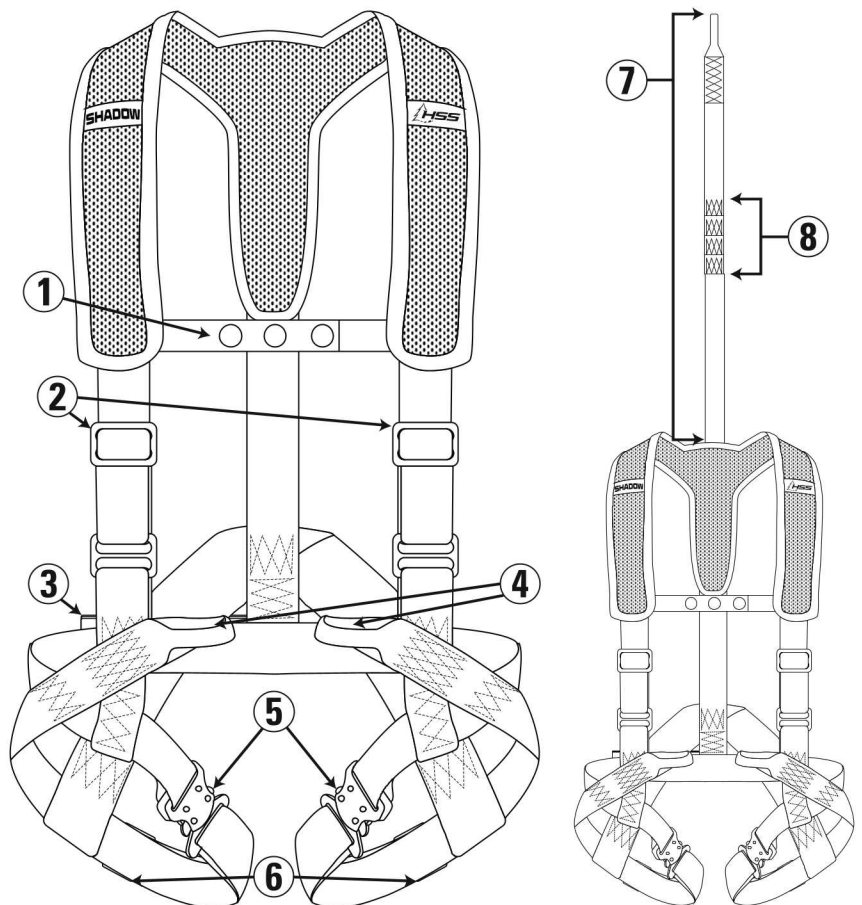

## WARNING!

Read, watch, understand and follow all written and DVD instructions before using any HSS product! Failure to do so could cause serious injury or death! If there is ANYTHING you do not thoroughly understand, or you have ANY questions about these instructions or the safe use of any HSS product, please call 877-296-3528 and speak with an HSS product specialist BEFORE using any HSS product!!!

Although Hunter Safety System, Inc. (HSS) is dedicated to manufacturing only the safest hunting equipment possible, this life-saving goal cannot succeed without the aid of our customers. Common sense in the use and understanding of this product is absolutely necessary.

**IMPORTANT/CAUTION:** The utilization of safe hunting practices and safe hunting equipment are the most important elements of the hunting experience and are your responsibility.

**QUESTIONS? CALL A PRODUCT SPECIALIST 1-877-296-3528**

## ADJUSTING YOUR HARNESS

1. Put the SHADOW harness on and securely fasten the chest strap. The chest strap snaps are intended to break loose during a fall to eliminate any possibility of a choking hazard.
2. Release each leg strap buckle, bring them between your legs, and securely snap them in place putting the left strap to the left leg buckle and right strap to the right leg buckle. Listen for a secure and complete snap indicating they are locked in place. Grab both sides of each buckle and pull sharply to make certain they are locked and secure with no clothing caught in the buckle. **WARNING!** Both leg buckles **MUST** be used whenever the harness is worn.
3. Adjust each leg strap length making the webbing comfortably snug to the leg. If a large adjustment is necessary, it may be easier to do so prior to snapping the buckles in place.
4. Adjust each shoulder strap making the webbing comfortably snug to the body.

## ATTACHING YOUR HARNESS TO THE TREE

1. Run the loose end of the Tree Strap through the loop located at the end of the harness tether. Immediately wrap the Tree Strap around the tree and secure the buckle as follows (**FIGURE 2**):

- a. With the bent "sides" up, thread the Tree Strap end from the back side between the sewn portion of the Tree Strap and the knurled slide bar.
- b. Bring the Tree Strap over the knurled slide bar and insert the Tree Strap between the knurled slide bar and the end of the buckle. (Figure 2)
- c. Pull tight to the tree and test attachment by pulling sharply on the tether and Tree Strap connection making sure it's secured tight to the tree. After securing the Tree Strap to the tree, there must be at least 8-inches of slack webbing beyond the buckle.

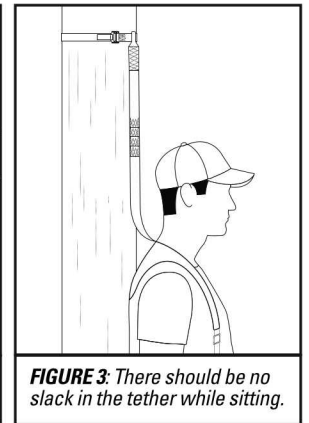
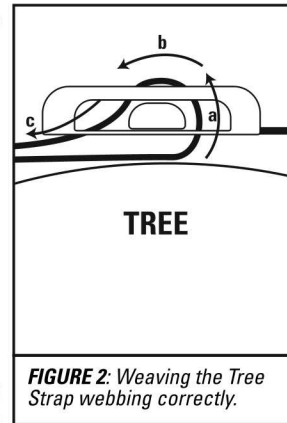

2. Locate the tree strap at a height that allows for no slack in the tether while in the sitting position (**FIGURE 3**). This is often at or just above head height while standing on the treestand.
3. **WARNING!** Always carry the Tree Strap in an easily accessible pocket.
4. **WARNING!** Do not run the tree strap through the loop at the end of your tether until you are securing yourself to the tree. DO NOT leave your tree strap attached to your tether when traveling or climbing. This will cause a dangling strap which could result in serious injury or death
5. **WARNING!** If the harness model you have does not have pockets and you choose not to purchase a pocket accessory, you **MUST** use a pocket in your outer clothing to ensure your straps are with you at all times.

## USING THE SUSPENSION RELIEF STRAP / DEER DRAG

1. A one-inch strap is attached to your harness to be used **ONLY** as a Suspension Relief Strap or Deer Drag. You will find this strap bundled by Velcro on the user's rear right-hand side.

**WARNING!** NEVER use this or the attached Suspension-Relief Strap as a means of securing yourself to the tree.

2. Practice at least one self-recovery and suspension relief method while near ground level and in the presence of a responsible adult.
3. If you fall and must remain suspended for an extended period of time while waiting for help to arrive, the Suspension-Relief Strap can allow the user to relieve the load on the lower body while suspended in the harness and help maintain blood circulation in the legs.
4. While suspended, open the Velcro closure located at the rear right-hand side of the harness. This gives you access to the Suspension-Relief Strap. Adjust the strap to a length that will allow you to place one of your feet into the loop and stand, relieving pressure caused by being suspended (**FIGURE 4**).



**FIGURE 4:** Adjust the strap to a length that will allow you to place one of your feet into it and stand relieving pressure caused by being suspended.

5. ALWAYS use your Suspension-Relief Strap when suspended for any period of time. If for some reason you are unable to use the Suspension-Relief Strap while suspended, be sure to move your legs often by bending your legs at your knees and waist to maintain a good blood flow. In addition to a Suspension-Relief Strap, always carry a screw-in step in an easily accessible pocket that can be screwed into the tree and stepped onto to relieve suspension trauma.

**QUESTIONS? CALL A PRODUCT SPECIALIST 1-877-296-3528**

## USING THE SUSPENSION RELIEF STRAP / DEER DRAG (CONTINUED)

6. Always keep an emergency signal device such as a whistle or small air horn in addition to a cell phone or personal locator beacon in an accessible pocket at all times so that you can contact someone for help.
7. **WARNING!** In the event of a fall, DO NOT PANIC! Put your practiced self-recovery plan into action, i.e., suspension relief, self-recovery, or other means of rescue.
8. To use the Suspension-Relief Strap as a deer drag, place the adjustable loop around the antlers or neck of the harvested animal and lean forward as you pull the animal, utilizing the harness to distribute the load.
9. **WARNING!** Always make sure the animal is not alive and never drag an animal or any weight if you presently have or you have ever experienced problems with you heart, respiratory system, back, legs, bones, or muscles.

## USE WITH VARIOUS TREESTAND STYLES

When using a climbing treestand, be sure to follow the treestand manufacturer's instructions and warnings with regards to proper usage. Make sure you attach your harness tether and tree strap securely to the tree while at ground level and advance the tree strap up or down as you ascend or descend staying connected to the tree at all times. Always keep the attachment point as high as possible on the tree. Test your tree attachment by pulling on the tether with each advancement to make certain it is tight.

If using a ladder stand, make sure you comply with the manufacturer's instructions and warnings. Once the ladder stand is erected and you have gained access to the platform, it is critical that you attach your tree strap and tether to the tree before engaging in further activities. In order to regain access to the platform in the event of a fall, it is critical that the tree strap is connected so there is no slack in the tether when in the sitting position. (Figure 3). Important! The manufacturer strongly recommends the use of a Hunter Safety System Lifeline when using a ladder stand to stay attached to the tree from the moment you leave the ground to the moment you return.

When using a hang-on style treestand, be sure to follow the treestand manufacturer's instructions and warnings with regard to proper usage. When ascending to an existing hang-on style treestand you must stay attached to the tree from the moment you leave the ground until you return. This must be accomplished with the optional HSS Lifeline or optional HSS Lineman's Climbing Strap and the provided tree strap with tether connection staying doubly attached. Upon reaching the stand, connect the tree strap and tether above the stand, disconnect the Lineman's Climbing Strap, and reconnect it above the stand. Remain doubly attached when stepping down into the center of the stand. Once secured in the stand, you can remove the Lineman's Climbing Strap.

**WARNING!** When using the Hunter Safety System Lifeline or Lineman's Climbing Strap (sold separately), you must follow all Lifeline, Lineman's Climbing Strap, and harness instructions.

**WARNING!** Anytime the harness's tether is not attached to the tree as per the Hunter Safety System Lineman's Climbing Strap instructions, the harness, when used with the HSS Lineman's Climbing Strap, should be considered a climbing aid only and NOT a fall restraint device. NOTE: While the SHADOW Harness does not come standard with a Lineman's Climbing Strap, it does have loops on the harness that are connection points for this strap. These loops are located above and to the side of the leg strap buckles (FIGURE 1, PAGE 2).

**WARNING!** When using a Lineman's Climbing Strap with this harness, it MUST be a Hunter Safety System brand Lineman's Climbing Strap.

## OVERALL SAFE USE INSTRUCTIONS AND HUNTING PRACTICES

**WARNING!** Read, watch and follow all instructions prior to using this harness. Failure to read, watch, understand and follow this information can cause serious injury or death! Call 1-877-296-3528 and speak with an HSS product specialist before using your Hunter Safety System harness if there is anything you do not understand!

**REMEMBER!** Safety and safe hunting practices are the most important elements of the hunting experience and are your responsibility. If there is anything about this product, it's use or any of the safety instructions that you do not fully understand, call 1-877-296-3528 and speak with an HSS product specialist before using these products.

Several optional products/systems are available that offer self-recovery or self-extraction from a fall when suspended in a harness. Some systems automatically descend the user while others allow user control. One of these products/ systems could be considered for use as an additional safety precaution against prolonged suspension and suspension trauma. Be sure to follow the manufacturers' directions on the safe use of these products/systems.

**WARNING!** This harness is certified to hold up to 300 pounds (hunter plus equipment). Do not exceed this weight limit.

To clean your harness: hand wash with mild soap and water. Keep leg buckles dry. Do not use in a washing machine or dryer.

**QUESTIONS? CALL A PRODUCT SPECIALIST 1-877-296-3528**

## OVERALL SAFE USE INSTRUCTIONS AND HUNTING PRACTICES (CONTINUED)

Prior to using the Hunter Safety System harness, make sure you read, understand and follow all safe-use instructions, warnings and the product expiration date. Watch the enclosed instructional DVD. If there are any questions concerning the proper use of this or any HSS product or anything you do not understand in the written or video safe-use instructions, call 1-877-296-3528 and speak with an HSS product specialist BEFORE using it.

When hunting from an elevated position, falls can occur any time after leaving the ground causing injury or death. ALWAYS wear your SHADOW harness and use any additional HSS accessory such as a LifeLine or Lineman's Climbing Strap to stay connected to the tree from the moment you leave the ground until you return to the ground. If you cannot wear your full body safety system for any reason, you MUST hunt from the ground.

Keep the provided, hang-tag/booklet of safe use instructions with you at all times while hunting for reference. Refer to the safe use instructions annually or anytime you are not certain about anything regarding your SHADOW harness. If there is anything you are not certain about, call 1-877- 296-3528 and speak with an HSS product specialist before using your safety system. Also, you MUST give the complete safe use and instructional material to anyone to whom you loan or sell your harness/safety system.

Familiarize yourself with the SHADOW harness and all its adjustments while at ground level. Also, while slightly above ground level and in the presence of a responsible adult, practice using your safety system to experience the feeling of hanging suspended before using in a hunting environment (**FIGURE 4, PAGE 3**).

**WARNING!** NEVER exceed the total weight limit (yourself and gear) specified for the particular model harness you are using.

The SHADOW harness is designed to arrest a single fall only. If you experience a fall while wearing this product, the harness must be discarded.

**WARNING!** DO NOT use this product or hunt from an elevated platform while using drugs of any type without approval from your personal physician - or after the consumption of any amount of alcohol. These substances can impair your balance, judgment and ability to safely hunt from an elevated position.

**WARNING!** DO NOT modify, repair, alter, sew, or cut this product in any way. Doing so may cause serious injury or death.

**WARNING!** DO NOT use this product or hunt from an elevated platform unless you are well rested and alert.

**WARNING!** DO NOT use this product if you have in the past or are presently experiencing any back or heart problems or medical condition that could cause a problem while above ground level. You MUST be physically and mentally able to safely recover to the stand's platform or ground in the event of a fall.

**WARNING!** Never hunt from an elevated position during inclement weather such as rain, lightning, high wind or icy conditions. Always end your hunt and return to the ground immediately if inclement weather conditions arise.

Anytime you are ascending, descending, or hunting from an elevated platform, make sure that you are secured to the tree from the moment you leave the ground until the moment you return to the ground. This should be accomplished with the use of one or more of the following: The HSS Lineman's Climbing Strap and Tree Strap combination (to stay doubly attached to the tree), or the optional HSS Lifeline. If lost or damaged, the HSS LifeLine or Lineman's Climbing Strap can be purchased at sporting goods stores or [www.huntersafetysystem.com](http://www.huntersafetysystem.com).

Always use the HSS Lineman's Climbing Strap (sold separately) and Tree Strap according to the manufacturer's instructions when hanging a fixed position, hang-on style treestand. If lost or damaged, they can always be purchased separately at sporting goods stores, by calling 1-877-296-3528 or [www.huntersafetysystem.com](http://www.huntersafetysystem.com).

The Lineman's Climbing Strap (sold separately) must always be used in conjunction with the Tree Strap and tether provided with the HSS vest/harness. To maximize safety, always attach the safety system's tether and Tree Strap to the tree along with the Lineman's Climbing Strap, staying doubly attached while climbing, hanging, or securing a hang-on style treestand, ladder stick or other accessories to or from a tree.

Always maintain a 3-point contact when climbing up or down a tree using climbing aids. Proper 3-point contact means having either two feet with one hand or one foot with two hands on the steps of your climbing aid at all times when climbing up/down or in and out of the treestand.

When moving to gain access into the treestand with the Lineman's Climbing Strap and tether/Tree Strap still attached to the tree, remove and reattach the HSS Tree Strap to the tree at a point located above the treestand before disconnecting the Lineman's Climbing Strap. Once securely attached to the tree by the tether/Tree Strap, remove the Lineman's Climbing Strap and climb above the base of the treestand.

If there is **ANYTHING** about this product or instructions that you do not fully understand,  
CALL 1-877-296-3528 to speak with a product specialist **BEFORE** using!

**QUESTIONS? CALL A PRODUCT SPECIALIST 1-877-296-3528**

## OVERALL SAFE USE INSTRUCTIONS AND HUNTING PRACTICES (CONTINUED)

Reattach the Lineman's Climbing Strap to the tree and stay doubly attached to the tree while stepping down into the center of the treestand. Remain doubly attached until you are secure in the stand. Then remove the Lineman's Climbing Strap and remain attached with the tether/Tree Strap. Only while advancing above or below a limb or treestand should either the Tree Strap or Lineman's Climbing Strap be temporarily removed and then only removed one at a time. Stay connected!

The SHADOW harness is only considered a fall restraint device when all chest and leg buckles are closed securely and adjusted comfortably snug in place around the body, and the harness/safety system is attached firmly to the tree by the tether according to HSS instructions.

Anytime you are above ground level, both leg straps and buckles must be correctly adjusted and in the proper position between your legs (left strap/left leg, right strap/right leg). The chest strap must be snapped and the leg straps must be locked closed (and checked by pulling sharply on the leg buckles).

**WARNING!** The Suspension Relief/ Deer Drag located on the lower-right rear portion of the harness is to be used as a deer drag or suspension relief device ONLY. This should NEVER be used to attach or secure yourself to the tree.

**WARNING!** Inspect belts, buckles and tree straps prior to each use. Do not use this harness if any of these components is not working properly or shows signs of damage or wear.

**WARNING!** If you have purchased this harness in a sealed package with all instructions, warnings and items listed on page 2 of this instructional booklet, the harness must be removed from service five years from the date of purchase (be sure to keep your proof of purchase). If you have purchased or obtained this harness as a previously-owned harness, it must be removed from service five years from the date of manufacture. This date is printed on the tether label.

Prepare and practice a rescue, relief and recovery plan should a fall occur. Plan ahead on how you will recover and return to the stand platform or ground in the event of a fall. If a fall occurs, DO NOT PANIC! Remain calm and implement your practiced rescue, relief and recovery plan. Always carry a folding screw-in tree step and emergency whistle, two-way radio, or cell phone in an accessible pocket of your outer clothing for self-rescue use in the event of a fall. Hanging suspended for extended periods of time can cause discomfort, serious injury, or death.

Always inform someone of your hunting location and when to expect your return. Always carry a cell phone or personal locator beacon in case you need help.

Always hunt from the ground when self-recovery/escape ability is absent.

Never climb up/down or hunt at heights at which you are not completely comfortable.

Never connect your harness to any part of the treestand, climbing aids, or tree limbs.

Never use your harness to lean out from the treestand for any reason including trimming branches or shooting.

NEVER climb a dead, dying, leaning, icy, wet, or loose-barked tree. If in doubt as to the condition of the tree, DO NOT CLIMB IT! Never rely on a tree branch for support. Never climb or hunt from a utility pole.

User must be 16-years old or older and be physically and mentally able to use the SHADOW harness without adult supervision and assistance in adjustments, attachments to the tree, and all other concerns relating to the SHADOW harness. User must be physically and mentally able to recover after a fall has occurred.

**WARNING!** Persons under 16 years of age must be instructed prior to each use and supervised during use on all safety aspects of use by a responsible adult.

**WARNING!** Any person under 16 years of age wearing a SHADOW harness MUST be accompanied by a supervising adult at all times. This is especially important when positioned in a treestand or any platform located above ground level, while ascending to the treestand or descending from it or anytime it is being worn. Let's protect our youth!

**WARNING!** Never wrap the harness's tether around or across your neck or under your arms. This could result in serious injury or death.

To receive the industry's safe treestand video, call HE Tools at 801-466-9222 or NBEF at 479-649-9036.

### SAFETY FIRST!

Follow ALL safety instructions and warnings when wearing a Hunter Safety System Harness.  
If there is ANYTHING you do not thoroughly understand about these instructions or the safe use of this product,  
call 1-877-296-3528 and speak with an HSS product specialist BEFORE using it!

## QUESTIONS? CALL A PRODUCT SPECIALIST 1-877-296-3528

# LIMITED WARRANTY

This warranty is to the original retail purchaser and covers all materials and labor for the repair or replacement of the product due to defects in workmanship or materials within (1) one year from the date of purchase. This warranty does not cover use or care other than that described in instructions on hang tags and Tree Strap. Purchaser must read, follow and understand all safety and warranty instructions prior to use. Warning! If there is anything you do not understand about this product, its usage or instructions, call 1-877-296-3528 BEFORE using! Hunter Safety System, Inc. reserves the right to determine whether the product shall be repaired or replaced with a like or similar product. All shipping costs are the responsibility of the owner. Defective product, along with proof of purchase, should be sent to: Hunter Safety System, Inc., 8237 Danville Road, Danville, AL 35619.

THE FOREGOING IS IN LIEU OF ALL OTHER WARRANTIES, WHETHER EXPRESSED OR IMPLIED (INCLUDING THOSE OF MERCHANTABILITY AND FITNESS OF ANY OTHER PRODUCT FOR A PARTICULAR PURPOSE), AND ANY OF THE OTHER OBLIGATIONS OR LIABILITIES ON THE PART OF THE COMPANY.

# LIMITATION OF LIABILITY

It is expressly understood that the liability of Hunter Safety System, Inc. for its products, whether due to breach of warranty, negligence, strict liability, or otherwise, is limited to the repair of the product, and Hunter Safety System, Inc. will not be liable for any other injury, loss, or damage to material, arising in connection with the sale, installation, use of, inability to use, or the repair or replacement of Hunter Safety System, Inc. products. Hunter Safety System, Inc. accepts NO responsibility for injury or damage incurred when product has been altered or misused (not used according to instructions—for intended purpose).

Hunter Safety System, Inc. reserves the right at any time to make alterations or modifications to its products which, in its opinion, may improve the performance and efficiency of the product. HSS, Inc. shall not be required to make such alterations or modifications to products already in service.

HUNTER SAFETY SYSTEM, INC.

P. O. BOX 31

DANVILLE, AL 35619

To validate warranty, complete the warranty card below and return to above address. You may also submit the warranty form online at [www.huntersafetysystem.com](http://www.huntersafetysystem.com)



## WARRANTY CARD

Please send completed warranty cards to:  
Hunter Safety System, INC  
P.O. Box 31 Danville, AL 35619

NAME: \_\_\_\_\_

ADDRESS: \_\_\_\_\_

CITY: \_\_\_\_\_ STATE: \_\_\_\_\_ ZIP: \_\_\_\_\_

PHONE: \_\_\_\_\_ EMAIL: \_\_\_\_\_

DATE AND LOCATION OF PURCHASE: \_\_\_\_\_ SIZE PURCHASED: \_\_\_\_\_

TOP 3 OUTDOOR TV PROGRAMS: \_\_\_\_\_

TOP 3 OUTDOOR MAGAZINES: \_\_\_\_\_

HOW DID YOU FIND OUT ABOUT THIS PRODUCT? \_\_\_\_\_

*"BY SIGNING THIS WARRANTY CARD, I ATTEST THAT I HAVE VIEWED AND FULLY UNDERSTAND ALL WRITTEN AND VIDEO INSTRUCTIONS, AND IN THE EVENT OF A FALL WHILE WEARING THE SHADOW HARNESS, I AM PHYSICALLY ABLE TO RECOVER SAFELY TO THE TREESTAND, CLIMBING DEVICE, OR GROUND AND WILL MAINTAIN THAT ABILITY ANYTIME THE HSS HARNESS IS WORN."*

SIGNATURE: \_\_\_\_\_ DATE: \_\_\_\_\_

Please use the back of this comment card to write down comments and suggestions. Thank you! - Hunter Safety System

